

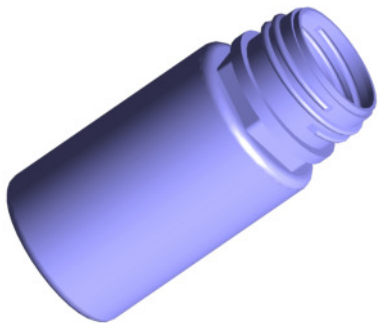

2:1
D

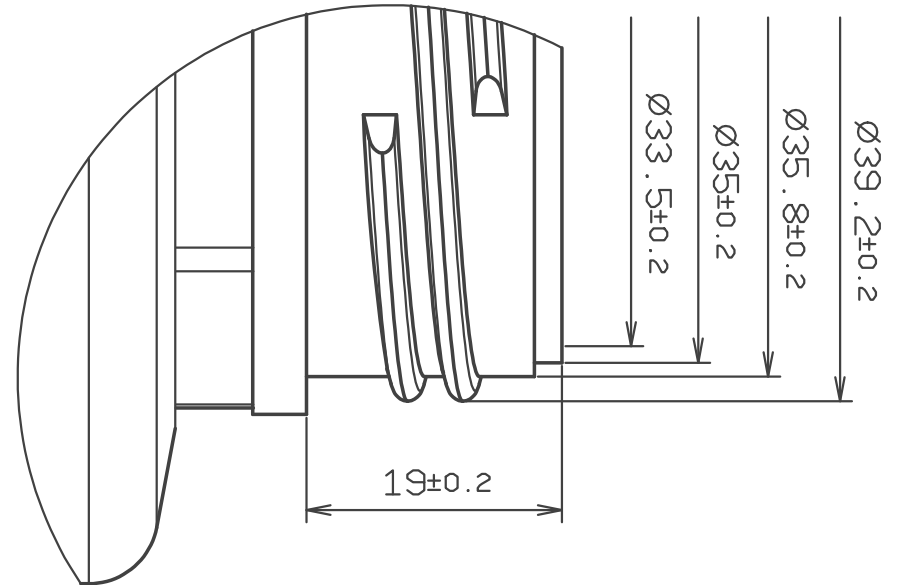

 <p>Flaschen Verschlüsse Ressel GmbH Tel.: +49 5144 627 www.ressel.eu</p>	Material: HD - PE		Gewicht: gr +/- 2
	Verpackungseinheit: Stück / Karton		
	Erstellt von: R. Ressel	Erstellungsdatum: 28/09/2010	Maßstab: 1:1
Artikelname: 19 / 125 / 40		Vergütung:	
		Oberflächenbehandlung.:	
Kunden Artikel Nr.:		<i>vorbehaltl. techn. bedingter Aenderungen</i>	