

b  
2:1

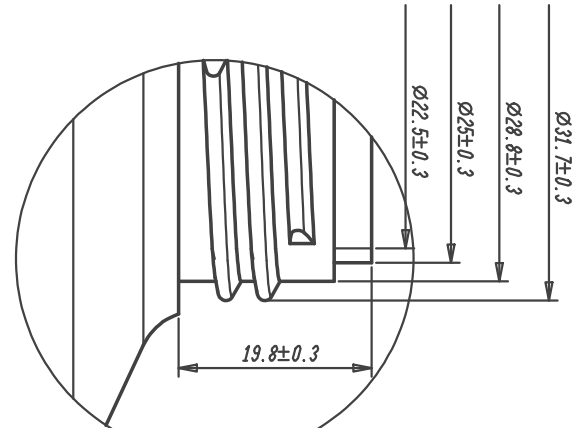

|   |  |   |
|---|--|---|
|  Flaschen<br>Verschlüsse<br>Ressel GmbH<br>Tel.: +49 5144 627<br>www.ressel.eu | Material: <b>HD - PE</b>                     | Gewicht: <b>gr +/- 2</b>                          |
|   | Verpackungseinheit: <b>94 Stück / Karton</b> |   |
| Erstellt von:<br>R. Ressel  | Erstellungsdatum:<br>12/01/2017              | Maßstab:<br>1:1                                   |
| Artikelname:<br><b>54 / 1000 / 32</b>   |  | Volumen:<br><Vergütung>                           |
|   |  | Oberflächenbehandlung:<br><Oberflächenbehandlung> |
| Kunden Artikel Nr.:<br><b>&lt;Teilenummer&gt;</b>   |  | <i>vorbehaltl. techn. bedingter Aenderungen</i>   |